

1080A Stainless Steel (CF8M / S.S 316) Three Piece Design Ball Valve, Class-150 (Screwed)

Salient Features

- Design Standard BS EN ISO 17292 (BS 5351).
- Screwed Female Ends to BSPT / NPT / Socket Weld.
- Reduced Bore, Three Piece Design.
- Superb in Quality and Performance.

Test Pressure (Hydrostatic) :

Shell : 31 kg/cm²g (440 psig)

Maximum Working Pressure : 21 kg/cm²g (300 psig)

Seat (Pneumatic) : 7kg/cm²g (100 psig)

Maximum Working Temperature : 220°C

Suitable For

Steam, Water, Oil, Air, Gases



Materials

P.No.	Name of Part	Material of Construction	Specification	Qty.
1	Body	Stainless Steel	ASTM A 351 Gr. CF8M	1
2	Ball	Stainless Steel	ASTM A276 Type 316 / ASTM A 351 Gr. CF8M	1
3	Thrust Washer	PTFE 35% Carbon Filled	---	1
4	Stem	Stainless Steel	ASTM A276 Type 316	1
5	Packing Ring	PTFE 35% Carbon Filled	---	2
6	Gland	Stainless Steel	ASTM A276 Type 304	1
7	Cup Washer	Stainless Steel	ASTM A276 Type 304	2
8	Nut	H.T. Steel	ASTM A 194 Gr. 2H	2
9	Spring Washer	Spring Steel	EN 47 Gr. B	1
10	Lever	Carbon Steel	---	1
11	Body Seat Ring	PTFE	---	2
12	Gasket	PTFE	---	2
13	Spring Washer	Spring Steel	EN 47 Gr. B	8
14	Studs	Alloy Steel	ASTM A 193 Gr. B7	4
15	Nuts	H.T Steel	ASTM A 194 Gr. 2H	8
16	End Connector	Stainless Steel	ASTM A 351 Gr. CF8M	2

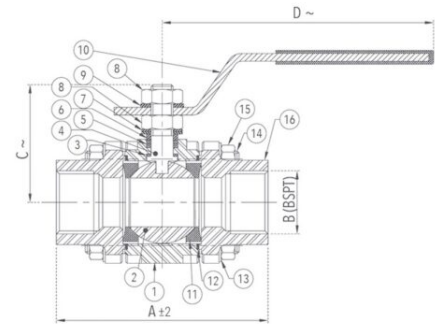

Sizes / Dimensions

Size (Inches)	Size (mm)	A ±2	B	C ~	D ~
1/2	15	69	1/2"	38	112
3/4	20	73	3/4"	40	125
1	25	95	1"	57	168
1 1/4	32	105	1 1/4"	65	168
1 1/2	40	115	1 1/2"	75	177
2	50	128	2"	80	220

~ ±10

1080B Stainless Steel (CF8M / S.S 316) Three Piece Design Ball Valve, Class-150 (Flanged)

Salient Features

- Design Standard BS EN ISO 17292 (BS 5351).
- Flanged Ends to ASME B B16.5 Class - 150 (Drilled).
- Three Piece Design.
- Superb in Quality and Performance.

Test Pressure (Hydrostatic) :

Shell : 31 kg/cm²g (440 psig)

Maximum Working Pressure : 21 kg/cm²g (300 psig)

Seat (Pneumatic) : 7 kg/cm²g (100 psig)

Maximum Working Temperature : 220°C

Suitable For

Steam, Water, Oil, Air, Gases



Materials

P.No.	Name of Part	Material of Construction	Specification	Qty.
1	Body	Stainless Steel	ASTM A 351 Gr. CF8M	1
2	Ball	Stainless Steel	ASTM A 276 Type 316 / ASTM A 351 Gr. CF8M	1
3	Thrust Washer	PTFE 35% Carbon Filled	---	1
4	Stem	Stainless Steel	ASTM A 276 Type 316	1
5	Packing Ring	PTFE 35% Carbon Filled	---	2
6	Gland	Stainless Steel	ASTM A 276 Type 316	1
7	Cup Washer	Stainless Steel	AISI A276 Type 316	2
8	Nut	H.T. Steel	ASTM A 194 Gr. 2H	2
9	Spring Washer	Spring Steel	EN 47 Gr. B	1
10	Lever	Carbon Steel	---	1
11	Body Seat Ring	PTFE	---	2
12	Gasket	PTFE	---	2
13	Spring Washer	Spring Steel	EN 47 Gr. B	8
14	Studs	Alloy Steel	ASTM A 193 Gr. B7	4
15	Nuts	H.T Steel	ASTM A 194 Gr. 2H	8
16	End Connector	Stainless Steel	ASTM A 351 Gr. CF8M	2

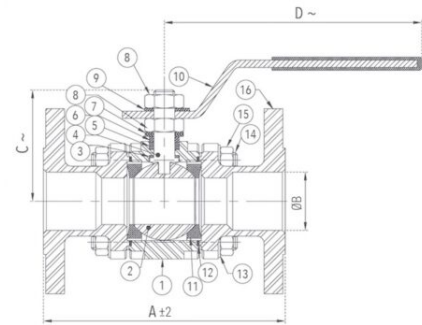

Sizes / Dimensions

Size (Inches)	Size (mm)	A ±2	B	C ~	D ~
1/2	15	108	15	38	150
3/4	20	117	20	40	150
1	25	127	25	57	160
1 1/4	32	140	32	65	160
1 1/2	40	165	40	75	202
2	50	178	50	75	202
2 1/2*	65	191	63.5	125	250
3*	80	203	76	137	335
4*	100	229	100	158	335

~ ±10

*Full Bore

1081 Stainless Steel (CF8 / S.S 304) Three Piece Design Ball Valve, Class-150 (Screwed)

Salient Features

- Design Standard BS EN ISO 17292 (BS 5351).
- Screwed Female Ends to BSPT / NPT / Socket Weld.
- Reduced Bore, Three Piece Design.
- Superb in Quality and Performance.

Test Pressure (Hydrostatic) :

Shell : 31 kg/cm²g (440 psig)

Maximum Working Pressure : 21 kg/cm²g (300 psig)

Seat (Pneumatic) : 7kg/cm²g (100 psig)

Maximum Working Temperature : 220°C

Suitable For

Steam, Water, Oil, Air, Gases



Materials

P.No.	Name of Part	Material of Construction	Specification	Qty.
1	Body	Stainless Steel	ASTM A 351 Gr. CF8	1
2	Ball	Stainless Steel	ASTM A276 Type 304 / ASTM A 351 Gr. CF8	1
3	Thrust Washer	PTFE 35% Carbon Filled	---	1
4	Stem	Stainless Steel	ASTM A276 Type 316	1
5	Packing Ring	PTFE 35% Carbon Filled	---	2
6	Gland	Stainless Steel	ASTM A276 Type 304	1
7	Cup Washer	Stainless Steel	ASTM A276 Type 304	2
8	Nut	H.T Steel	ASTM A 194 Gr. 2H	2
9	Spring Washer	Spring Steel	EN 47 Gr. B	1
10	Lever	Carbon Steel	---	1
11	Body Seat Ring	PTFE	---	2
12	Gasket	PTFE	---	2
13	Spring Washer	Spring Steel	EN 47 Gr. B	8
14	Studs	Alloy Steel	ASTM A 193 Gr. B7	4
15	Nuts	H.T Steel	ASTM A 194 Gr. 2H	8
16	End Connector	Stainless Steel	ASTM A 351 Gr. CF8	2

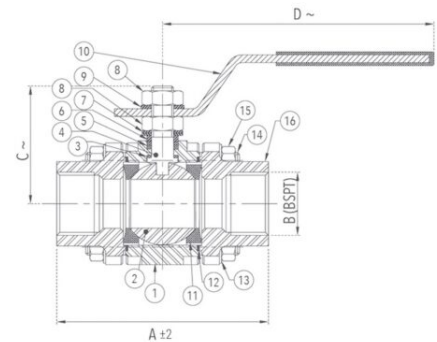

Sizes / Dimensions

Size (Inches)	Size (mm)	A ±2	B	C ~	D ~
1/2	15	69	1/2"	38	112
3/4	20	73	3/4"	40	125
1	25	95	1"	57	168
1 1/4	32	105	1 1/4"	65	168
1 1/2	40	115	1 1/2"	75	177
2	50	128	2"	80	220

~ ±10

1081A Stainless Steel (CF8 / S.S-304) Three Piece Design Ball Valve, Class-150 (Flanged)

Salient Features

- Design Standard BS EN ISO 17292 (BS 5351).
- Flanged Ends to ASME B B16.5 Class-150 (Drilled).
- Three Piece Design.
- Superb in Quality and Performance.

Test Pressure (Hydrostatic) :

Shell : 31 kg/cm²g (440 psig)

Maximum Working Pressure : 21 kg/cm²g (300 psig)

Seat (Pneumatic) : 7 kg/cm²g (100 psig)

Maximum Working Temperature : 220°C

Suitable For

Steam, Water, Oil, Air, Gases



Materials

P.No.	Name of Part	Material of Construction	Specification	Qty.
1	Body	Stainless Steel	ASTM A 351 Gr. CF8	1
2	Ball	Stainless Steel	ASTM A 276 Type 304 / ASTM A 351 Gr. CF8	1
3	Thrust Washer	PTFE 35% Carbon Filled	---	1
4	Stem	Stainless Steel	ASTM A 276 Type 316	1
5	Packing Ring	PTFE 35% Carbon Filled	---	2
6	Gland	Stainless Steel	ASTM A 276 Type 304	1
7	Cup Washer	Stainless Steel	AISI A276 Type 304	2
8	Nut	H.T Steel	ASTM A 194 Gr. 2H	2
9	Spring Washer	Spring Steel	EN 47 Gr. B	1
10	Lever	Carbon Steel	---	1
11	Body Seat Ring	PTFE	---	2
12	Gasket	PTFE	---	2
13	Spring Washer	Spring Steel	EN 47 Gr. B	8
14	Studs	Alloy Steel	ASTM A 193 Gr. B7	4
15	Nuts	H.T Steel	ASTM A 194 Gr. 2H	8
16	End Connector	Stainless Steel	ASTM A 351 Gr. CF8	2

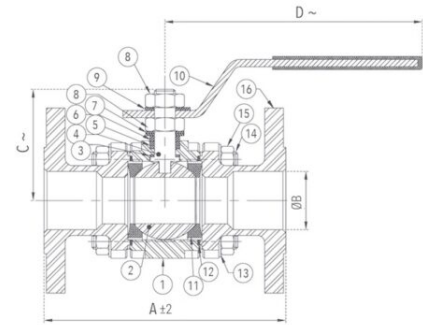

Sizes / Dimensions

Size (Inches)	Size (mm)	A ±2	B	C ~	D ~
1/2	15	108	15	38	150
3/4	20	117	20	40	150
1	25	127	25	57	160
1 1/4	32	140	32	65	160
1 1/2	40	165	40	75	202
2	50	178	50	80	202
2 1/2*	65	191	63.5	125	250
3*	80	203	76	137	335
4*	100	229	100	158	335

~ ±10

*Full Bore

1088 Cast Steel Three Piece Design Ball Valve, Class-150 (Screwed)

I.B.R

Salient Features

- Design Standard BS EN ISO 17292 (BS 5351).
- Screwed Female Ends to BSPT / NPT / Socket Weld.
- Reduced Bore, Three Piece Design.
- Superb in Quality and Performance.

Test Pressure (Hydrostatic) :
Shell : 31 kg/cm²g (440psig)
Seat : 21kg/cm²g (300 psig)
Seat (Steam) : 10.55 kg/cm²g (150 psig)
Maximum Working Temperature : 220°C

Suitable For

Steam, Water, Oil



Materials

P.No.	Name of Part	Material of Construction	Specification	Qty.
1	Body	Cast Steel	ASTM A 216 Gr. WCB	1
2	Ball	Stainless Steel	ASTM A 276 Type 304 / ASTM A 351 Gr. CF8	1
3	Thrust Washer	PTFE 35% Carbon Filled	---	1
4	Stem	Stainless Steel	ASTM A 276 Type 316	1
5	Packing Ring	PTFE 35% Carbon Filled	---	2
6	Gland	Stainless Steel	ASTM A 276 Type 304	1
7	Cup Washer	Stainless Steel	ASTM A 276 Type 304	2
8	Nut	H.T Steel	ASTM A 194 Gr. 2H	2
9	Spring Washer	Spring Steel	EN 47 Gr. B	1
10	Lever	Carbon Steel	---	1
11	Body Seat Ring	PTFE	---	2
12	Gasket	PTFE	---	2
13	Spring Washer	Spring Steel	EN 47 Gr. B	8
14	Studs	Alloy Steel	ASTM A 193 Gr. B7	4
15	Nuts	H.T Steel	ASTM A 194 Gr. 2H	8
16	End Connector	Cast Steel	ASTM A 216 Gr. WCB	2

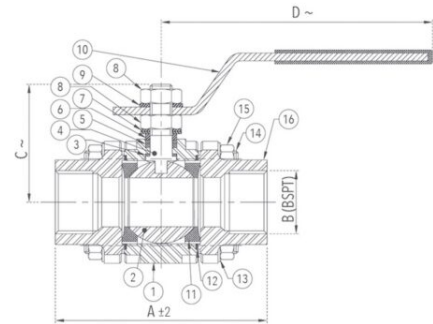

Sizes / Dimensions

Size (Inches)	Size (mm)	A ±2	B	C ~	D ~
1/2	15	69	1/2"	38	112
3/4	20	73	3/4"	40	125
1	25	95	1"	57	168
1 1/4	32	105	1 1/4"	65	168
1 1/2	40	115	1 1/2"	75	177
2	50	128	2"	80	220

~ ±10

1089 Cast Steel Three Piece Design Ball Valve, Class-150 (Flanged) ^{I.B.R}

Salient Features

- Design Standard BS EN ISO 17292 (BS 5351).
- Flanged Ends to ANSI B16.5 Class-150 (Drilled).
- Three Piece Design.
- Superb in Quality and Performance.

Test Pressure (Hydrostatic) :
Shell : 31 kg/cm²g (440 psig)
Seat : 21kg/cm²g (30 psig)
Seat (Steam) : 10.55 kg/cm²g (150 psig)
Maximum Working Temperature : 220°C

Suitable For

Steam, Water, Oil



Materials

P.No.	Name of Part	Material of Construction	Specification	Qty.
1	Body	Cast Steel	ASTM A 216 Gr. WCB	1
2	Ball	Stainless Steel	ASTM A 276 Type 304 / ASTM A 351 Gr. CF8	1
3	Thrust Washer	PTFE 35% Carbon Filled	---	1
4	Stem	Stainless Steel	ASTM A 276 Type 316	1
5	Packing Ring	PTFE 35% Carbon Filled	---	2
6	Gland	Stainless Steel	ASTM A 276 Type 304	1
7	Cup Washer	Stainless Steel	ASTM A 276 Type 304	2
8	Nut	H.T Steel	ASTM A 194 Gr. 2H	2
9	Spring Washer	Spring Steel	EN 47 Gr. B	1
10	Lever	Carbon Steel	---	1
11	Body Seat Ring	PTFE	---	2
12	Gasket	PTFE	---	2
13	Spring Washer	Spring Steel	EN 47 Gr. B	8
14	Studs	Alloy Steel	ASTM A 193 Gr. B7	4
15	Nuts	H.T Steel	ASTM A 194 Gr. 2H	8
16	End Connector	Cast Steel	ASTM A 216 Gr. WCB	2

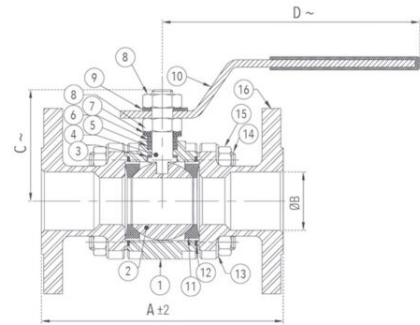

Sizes / Dimensions

Size (Inches)	Size (mm)	A ±2	ØB	C ~	D ~
1/2	15	108	15	38	150
3/4	20	117	20	40	150
1	25	127	25	57	160
1 1/4	32	140	32	65	160
1 1/2	40	165	40	75	202
2	50	178	50	80	202
2 1/2*	65	191	63.5	125	250
3*	80	203	76	137	335
4*	100	229	100	158	335

~ ±10

*Full Bore