

1071 Cast Steel Globe Steam Stop Valve (Flanged) ^{I.B.R.}

Salient Features

- Flanged Ends to DIN 2545 PN 40.
- Straight Pattern, Outside Screw, Yoke Type, Rising Stem, Bolted Bonnet.
- Renewable 13% Cr. Stainless Steel (S.S 410) working parts.
- Minimum pressure drop inside the body due to streamlined body design.
- Handwheel Operated.
- Provision for re-packing under pressure.
- Suitable for thermic fluid application also.

Test Pressure (Hydrostatic) :

Shell : 60 bar (870 psig)

Maximum Working Pressure : 40 bar (580 psig)

Maximum Working Temperature : 425°C

Suitable For

Steam, Water, Oil



Materials

P.No.	Name of Part	Material of Construction	Specification	Qty.
1	Nut	Carbon Steel	---	1
2	Washer	Carbon Steel	---	1
3	Handwheel	S.G Iron	IS 1865 Gr. 400 / 15	1
4	Stem	Stainless Steel	ASTM A 276 Type 410	1
5	Yoke Bush	Aluminium Bronze	BS EN 1982 AB - 1	1
6	Locking Screw	Carbon Steel	IS 1367	1
7	Gland Flange	Cast Steel	IBR 73-80 Gr. B	1
8	Gland	Stainless Steel	ASTM A 276 Type 410	1
9	Bonnet	Cast Steel	IBR 73-80 Gr. B	1
10	Gland Packing	Braided Graphite	---	-
11	Gasket	Spiral Wound S.S (Type 316) Graphite Filled	---	1
12	Back Seat Bush	Aluminium Bronze	BS EN 1982 AB - 1	1
13	Stem Nut	Stainless Steel	ASTM A 276 Type 410	1
14	Disc	Cast Steel	IBR 73-80 Gr. B	1
15	Seat Ring	Stainless Steel	ASTM A 276 Type 410 / ASTM A 182 Gr. F6a	1
16	Body Seat Ring	Stainless Steel	ASTM A 276 Type 410 / ASTM A 182 Gr. F6a	1
17	Body	Cast Steel	IBR 73-80 Gr. B	1
18	Nuts	H.T Steel	ASTM A 194 Gr. 2H	As Reqd
19	Studs	Alloy Steel	ASTM A 193 Gr. B7	As Reqd
20	Nuts For Eye Bolts	H.T Steel	ASTMA 194 Gr. 2H	2
21	Eye Bolts	Stainless Steel	ASTM A 182 Gr. F6a	2
22	Pins For Eye Bolts	Stainless Steel	ASTM A 276 Type 410	2

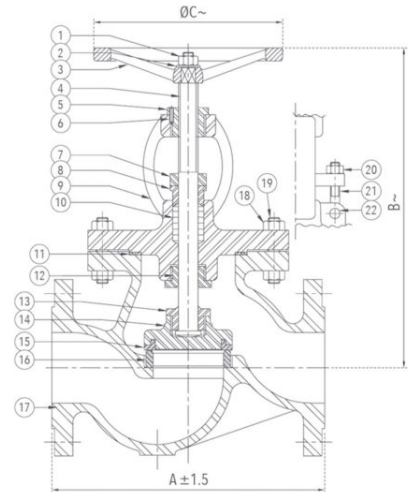

Sizes / Dimensions

Size (Inches)	Size (mm)	A ±1.5	B ~	ØC ~
1/2	15	130	190	120
3/4	20	150	190	120
1	25	160	215	150
1 1/4	32	180	230	150
1 1/2	40	200	259	180

Size (Inches)	Size (mm)	A ±1.5	B ~	ØC ~
2	50	230	272	180
2 1/2	65	290	316	200
3	80	310	341	235
4	100	350	395	295
6	150	480	500	350
8	200	600	525	435

~ ±10