

## 1089 Cast Steel Three Piece Design Ball Valve, Class-150 (Flanged) <sup>I.B.R</sup>

### Salient Features

- Design Standard BS EN ISO 17292 (BS 5351).
- Flanged Ends to ANSI B16.5 Class-150 (Drilled).
- Three Piece Design.
- Superb in Quality and Performance.

Test Pressure (Hydrostatic) :  
Shell : 31 kg/cm<sup>2</sup>g (440 psig)  
Seat : 21kg/cm<sup>2</sup>g (30 psig)  
Seat (Steam) : 10.55 kg/cm<sup>2</sup>g (150 psig)  
Maximum Working Temperature : 220°C

### Suitable For

Steam, Water, Oil



### Materials

P.No.	Name of Part	Material of Construction	Specification	Qty.
1	Body	Cast Steel	ASTM A 216 Gr. WCB	1
2	Ball	Stainless Steel	ASTM A 276 Type 304 / ASTM A 351 Gr. CF8	1
3	Thrust Washer	PTFE 35% Carbon Filled	---	1
4	Stem	Stainless Steel	ASTM A 276 Type 316	1
5	Packing Ring	PTFE 35% Carbon Filled	---	2
6	Gland	Stainless Steel	ASTM A 276 Type 304	1
7	Cup Washer	Stainless Steel	ASTM A 276 Type 304	2
8	Nut	H.T Steel	ASTM A 194 Gr. 2H	2
9	Spring Washer	Spring Steel	EN 47 Gr. B	1
10	Lever	Carbon Steel	---	1
11	Body Seat Ring	PTFE	---	2
12	Gasket	PTFE	---	2
13	Spring Washer	Spring Steel	EN 47 Gr. B	8
14	Studs	Alloy Steel	ASTM A 193 Gr. B7	4
15	Nuts	H.T Steel	ASTM A 194 Gr. 2H	8
16	End Connector	Cast Steel	ASTM A 216 Gr. WCB	2

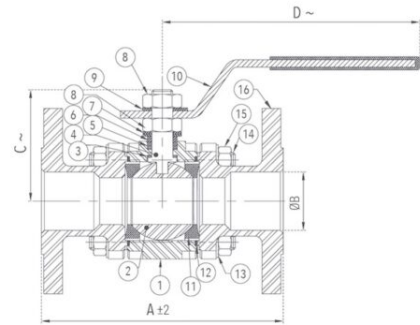

### Sizes / Dimensions

Size (Inches)	Size (mm)	A ±2	ØB	C ~	D ~
1/2	15	108	15	38	150
3/4	20	117	20	40	150
1	25	127	25	57	160
1 1/4	32	140	32	65	160
1 1/2	40	165	40	75	202
2	50	178	50	80	202
2 1/2*	65	191	63.5	125	250
3*	80	203	76	137	335
4*	100	229	100	158	335

~ ±10

\*Full Bore